

Hydraulic Components

Bellhousings

according to VDMA 24561 design A



- Links between IEC motor and hydraulic pump
- For almost every hydraulic pump either available from stock or in short term
- Both flange sides are finish machined
- Motor and pump shaft centered
- KTR bellhousings are made from aluminium
- In many cases KTR bellhousings can be piled up
- Designed for high loads
- For the bellhousing selection you require please either see our selection programme at www.ktr.com or order the selection stored on CD-ROM
- Bellhousing types made from steel on request
- Notice our mounting instructions

For IEC motor from size 225S
8 fixing holes are offset
22,5° on the verticle

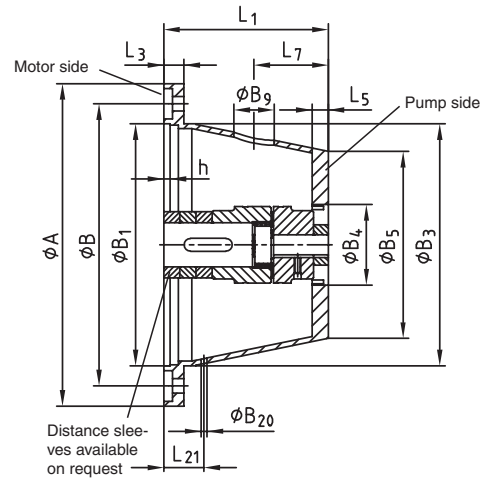
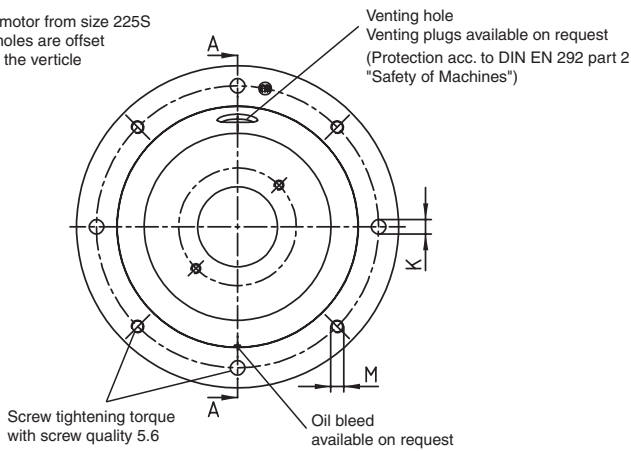

IEC - motor size (shaft end) d ₁ x l ₃	kW with n = 1500 1/min	Bell-housing Size	Gasket DP Size	Foot flange PTFE/PTFS *)	Dimensions [mm]														
					A	B	B ₁	B ₃	h	K	M	L ₁	L ₃	L ₅	B ₅	Min. B ₄	Venting hole B ₉	L ₇	Oil bleed B ₂₀
71 (14 x 30)	0,25	PK 160/5/..	160	160	160	130	110	110	4	9	M8	80	13	8	105	27	33	7,5	28
	0,37	PL 160/5/..										90			102	29	38		
80 (19 x 40)	0,55	PK 200/3/..	200	200	200	165	130	145	4	11	M10	100	16	12	124	40	43	7,5	36
	0,75	PL 200/3/..										110			124	37	47		
		PL 200/8/..										124			133	57	60		
90S / 90L (24 x 50)	1,1	PL 200/4/..	200	200	200	165	130	145	4	11	M10	124	16	12	144	40	54	7,5	36
	1,5	PFL 200/6/..										140			180	47	62		
100L / 112M (28 x 60)	2,2	PK 250/6/..	250	250	250	215	180	190	5	14	M12	120	18	12	180	74	54	7,5	43
		PL 250/3/..										124			124	42	52		
	3	PL 250/6/..										135			180	40	57		
	4	PL 250/4/..										148			166	56	64		
132S / 132M (38 x 80)	5,5	PK 300/5/..	300	300	300	265	230	234	5	14	M12	144	20	15	205	57	63	7,5	45
		PL 300/15/..										150			231	77	66		
	7,5	PK 300/4/..										168			166	56	50		
		PL 300/4/..										168			220	57	74		
160M / 160L (42 x 110) 180M / 180L (48 x 110)	11	PK 350/4/..	350	350	350	300	250	260	6	17	M16	188	25	15	230	56	82	7,5	51
	15	PK 350/6/..										204			251	97	102		
	18,5	PK 350/10/..										228			251	97	102		
		PL 350/7/..										256			258	74	115		
200L (55 x 110)	30	PK 400/4/..	400	400	400	350	300	300	6	17	M16	204	25	20	230	75	92	7,5	51
		PK 400/5/..										228			290	77	50		
	PL 400/5/..	256										290			97	118			

Please indicate in the order if the bellhousing is needed in oilproof design! (Extra charge)

*) For vertical assembly or lateral assembly on the tank gaskets are available (type DP, see page 163).

For the detailed order designation please see our PC/Internet selection programme or mention the IEC motor size and detailed pump type for selection.